



Features:

- CASAMBI Enabled Wireless Control
- DALI-2 Bus Powered
- Ceiling Mounted PIR Motion Sensor
- Daylight Sensor for Ambient Light Detection
- Adjustable Detection Area & Time Settings
- DALI / DT6 / DT7 Compatible
- ON / OFF Control via DALI or CASAMBI App
- IP20: Ingress Protection
- 5 year warranty



Model		SR-CS9030D-PIR-D
Input and Output	Operating Voltage	Powered by DALI BUS
	Output	DALI BUS
Mechanical Specifications	Dimensions	φ90*52mm
	Material	Flame-retardant/ABS
	Protection Class	II
Safety & EMC	EMC standard (EMC)	EN55015, EN6100, EN61547
	Safety standard (LVD)	EN60669-1, EN60669-2-1, AS/NZS60669-1/-2-1
	RED	EN300328, EN301489-1/-17
	Certification	ENEC, CE, EMC, RED, RC
Wireless Communication	Transceiver Frequency	2.4GHz ISM band
	Radio Range	164 feet (50m) in open field
	Radio Certification	FCC/IC, CE
Lighting Control	Features	DALI broadcast, Individual/group addressing, Scene control Autonomous sensor-based control, Scheduler control
Sensing	Movement Detection	Max. 8m @3m height
	Installation	Max. 6m
Connectors	Terminal block/Wire size	0.5mm ² - 1.5mm ² solid or stranded
	Wire strip length	6-7mm
Environment	Operating Temp. Range	-20°C to +50°C
	IP Rating	IP44 (Front-face)
Safety & Warnings	<ul style="list-style-type: none"> • DO NOT Install with power applied to the device • DO NOT expose the device to moisture 	
Notes	<ul style="list-style-type: none"> • PIR motion detection • Daylight harvesting • Works with DALI drivers or luminaires, broadcast control • Autonomous sensor-based control • Can be use for indoor applications 	

Mechanical Specifications

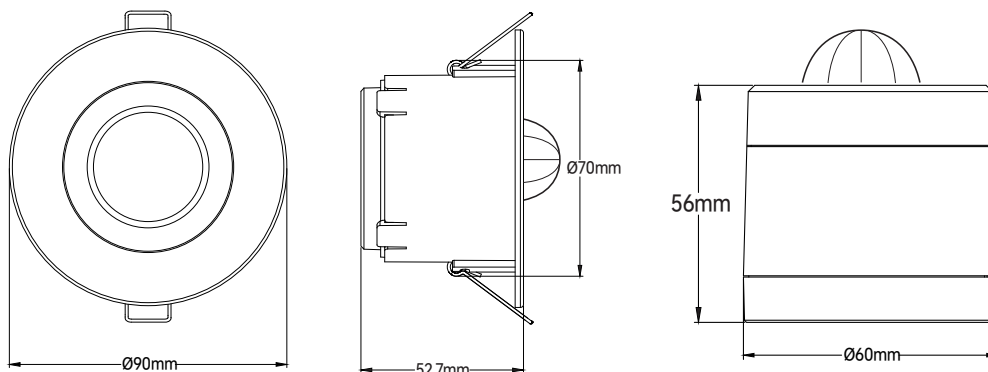

Detection Pattern

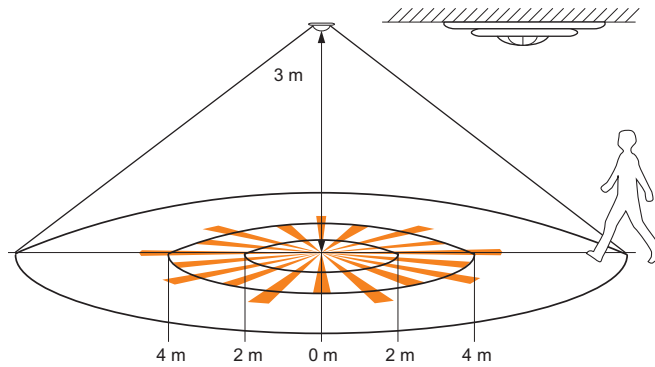

Coverage Side View

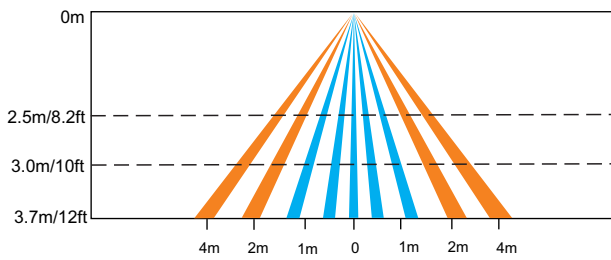

Coverage Top View

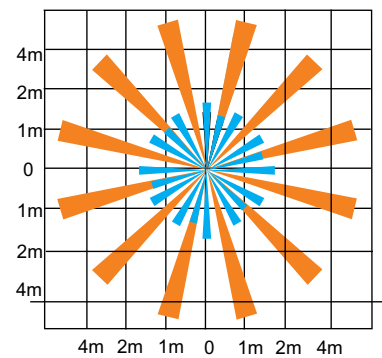

The detection area for movement can be roughly divided into two parts:

- Slow movement (person moving $< 1.0/s$ or $0.3m/s$)
- Quick movement (person moving $> 1.3/s$ or $0.4m/s$)

Place/Detection Instruction

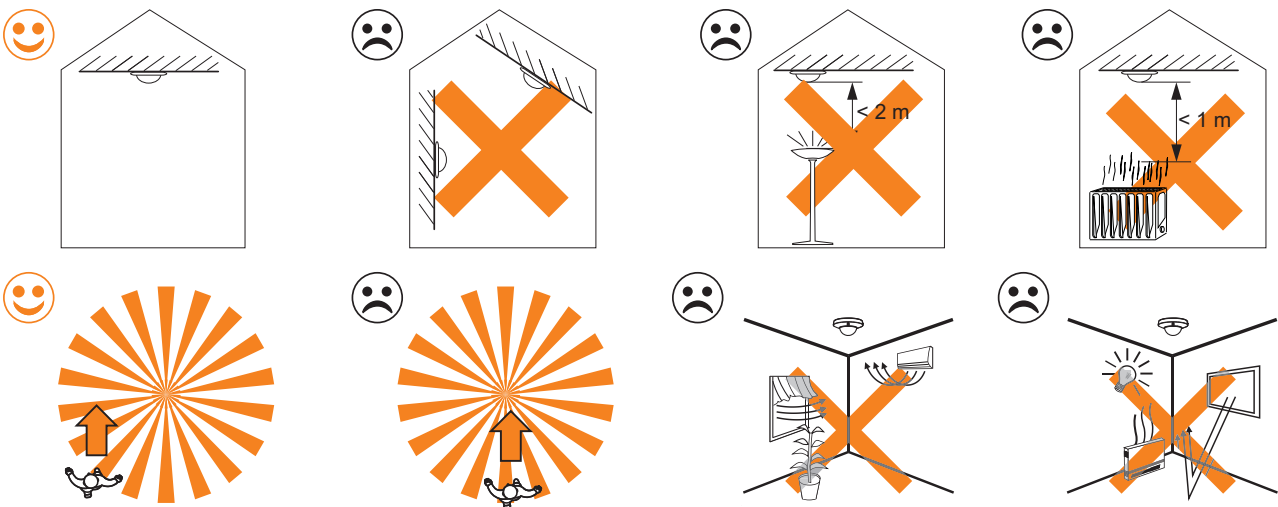

Application

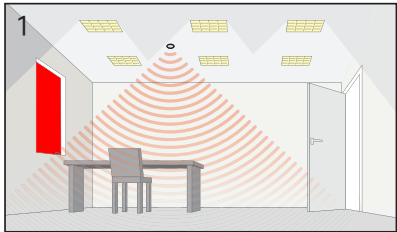

1. Power up the sensor. The load should come on immediately.

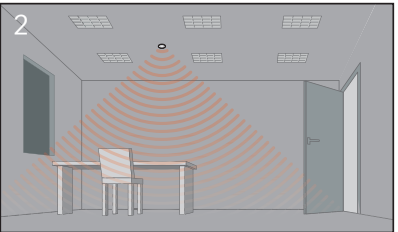

2. Vacate the room or remain very still and wait for the load to switch off.

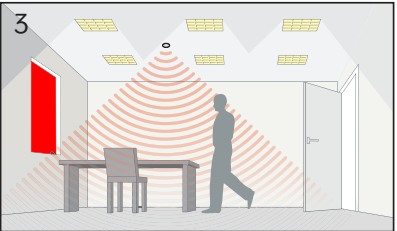

3. Enter the room or make some movement and check that the load switches on.

PRECAUTIONS

- Do not place the SENSOR near heat sources, fans or in ventilated ceiling voids.
- Do not place close to, or positioned such that, any light source points directly into the SENSOR.
- Ensure wires and cables are securely held within the connection terminals.
- Disconnect the SENSOR from the circuit before performing insulation testing of the wiring circuit.

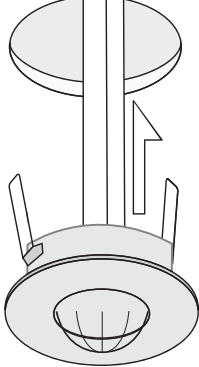

Bend the springs up and push detector through hole in ceiling. When fully inserted the springs snap back to hold the device in place. To avoid injury, take care when bending springs.

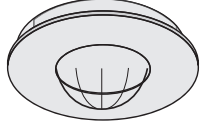

Installation complete.

Wiring Diagram

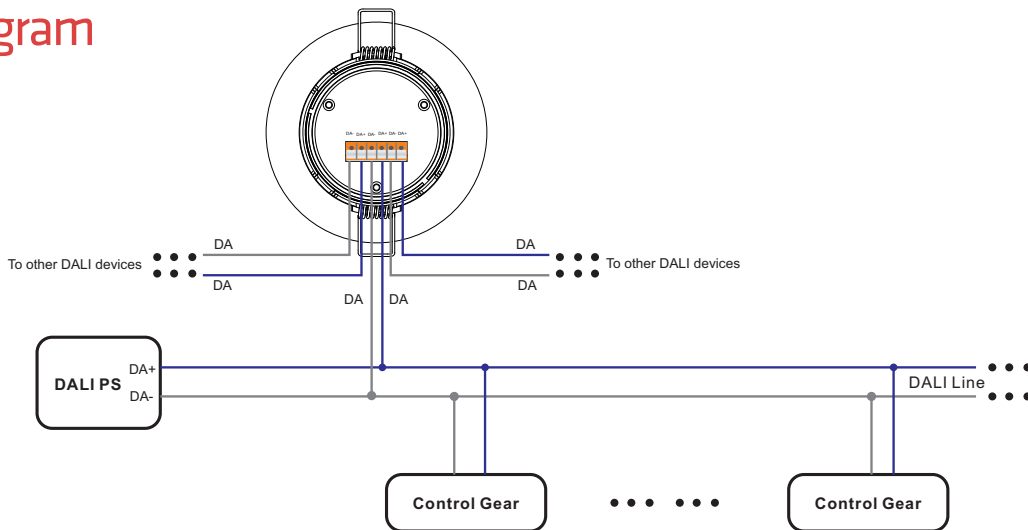

- Avoid areas with frequent temperature changes: Keep away from air conditioners, fans, refrigerators, ovens, and other objects that cause rapid temperature changes. The detection effectiveness of PIR motion sensors is closely related to temperature fluctuations, and vents or heat sources can lead to false alarms.
- Avoid areas with significant air flow.
- Avoid facing glass doors and windows directly:
 - 1) Do not face glass doors and windows directly to avoid interference from strong light.
 - 2) Avoid complex environments outside doors and windows, such as direct sunlight, crowds, and moving vehicles.
- Avoid installing opposite large, constantly moving objects: Large objects with significant motion can cause sudden changes in airflow within the detection area, leading to false alarms. Outdoor PIR motion sensors should not be installed opposite large trees or tall bushes.
- Avoid areas with screens, furniture, large potted plants, or other obstacles within the detection range.
- Avoid areas exposed to direct sunlight.