



**5 YEAR
WARRANTY**

150W
Multi-Dim
Phasecut +0-10V
Slimline
LED Driver
 with PWM
 Output

**Features of the:
LMVT-150 Series**



Constant Voltage PWM Output



IP20 Design For Indoor Installation



AC Input Range: 200-240VAC with PFC



Cooling by Free Air Convection



Protections:
 • Short Circuit
 • Over Load
 • Over Temperature



High Efficiency



Class II Power Supply



Triac +0-10V Dimming



CE     IP20 SELV CB

Model		LMVT-150-12	LMVT-150-24
Output	DC voltage	12V	24V
	Voltage tolerance	±0.5V (see Note 2.)	
	Rated current	12.5A	6.25A
	Rated power	150W	
Input	Voltage range	200-240VAC	
	Frequency range	47~63HZ	
	Power factor	0.96 @ 230VAC	
	Full load efficiency (Typ.)	90%	90%
	AC current (Max.)	0.95A	0.95A
	Leakage current	<0.50mA	
	Inrush current	47.5A, 50%, 312us	
	MAX. No. of drivers on 16A circuit breaker	4 units (circuit breaker of type B) / 6 units (circuit breaker of type C) at 230VAC	
Protection	Short circuit	Shut down o/p voltage, re-power on to recover after fault condition is removed	
	Over loading (Note 4.)	Hiccup mode, recovers automatically after fault condition is removed	
	Over temperature (Note 6.)	100°C± 10°C	
Environment	Working TEMP.	-40~+60°C (refer to de-rating curve)	
	Working humidity	20~95%RH, non-condensing	
	Storage TEMP., humidity	-40~+80°C, 10~95%RH	
	TEMP. coefficient	±0.03%/°C (0~50°C)	
	Vibration	10-500Hz, 5G 10min./1 cycle, period for 60min, each along X, Y, Z axes	
Safety & EMC	Safety standards	EN61347-1 EN61347-2-13 EN62493	
	Withstand voltage	I/P-O/P: 3.75KVAC	
	Isolation resistance	I/P-O/P: 100MΩ/500VDC/25°C/70%RH	
	EMC emissions (Note 3.)	EN55015, EN61000-3-2, EN61000-3-3	
	EMC immunity	EN61000-4-2,3,4,5,6, 11, EN61547	
Others	Net. weight	0.48kg	
	Size	368*30*22mm (L*W*D)	
	Packing	360*270*175mm/30PCS/CTN	
Notes	<ol style="list-style-type: none"> All parameters NOT specially mentioned are measured at 230VAC input, rated load and 25°C of ambient temperature. Tolerance: Includes set up tolerance, line regulation and load regulation. The LED driver is considered as a component that is operated in conjunction with final equipment. EMC performance could be affected by the complete installation. Original equipment manufacturers may need to conduct additional EMC testing and certification on the final equipment. Normal loading range from 10% to 100%. Specifications are subject to change without prior notice. Contact your supplier to confirm any critical parameters. Reading taken at tc point marked on product label. 		

Input & Output Terminals

Mechanical Specification

Input Terminals:
Suggested input wire size:
0.75mm² - 2.5mm²

Output Terminals:
Suggested output wire size:
0.5mm² - 2.5mm²

Dimming Terminals:
DIM (+) to 0/1-10V dimmer signal (+),
DIM (-) to 0/1-10V dimmer signal (-)
Suggested dimming wire size:
0.5mm² - 2.5mm²

Incorrect wiring could result in damage to the power supply, which is not covered by the warranty.

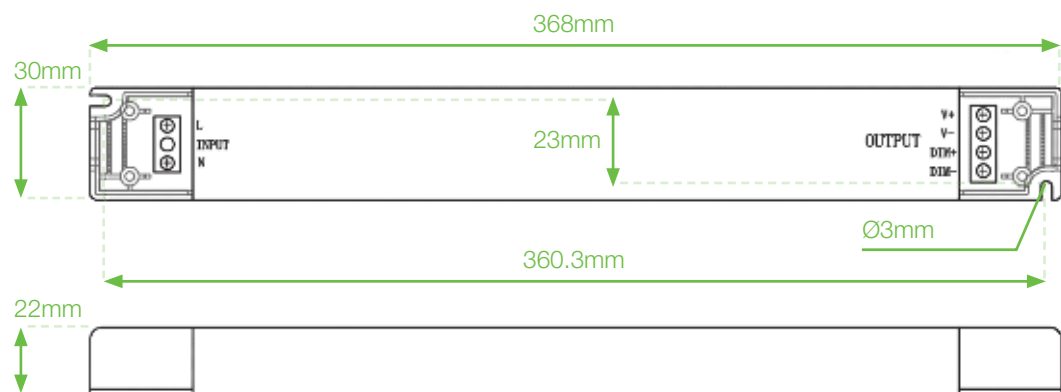

Dimming Operation

Phase Dimming Connection Diagram

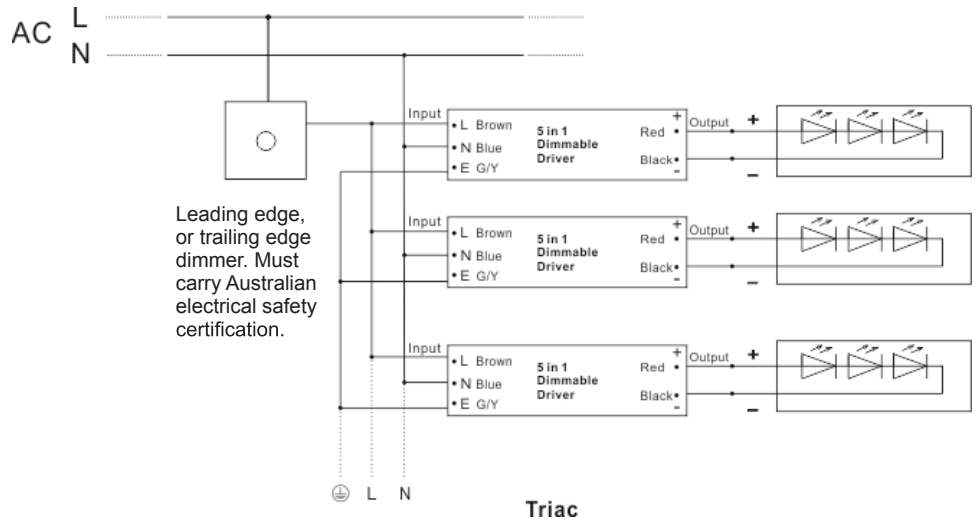

0-10V (1-10V) Connection Diagram

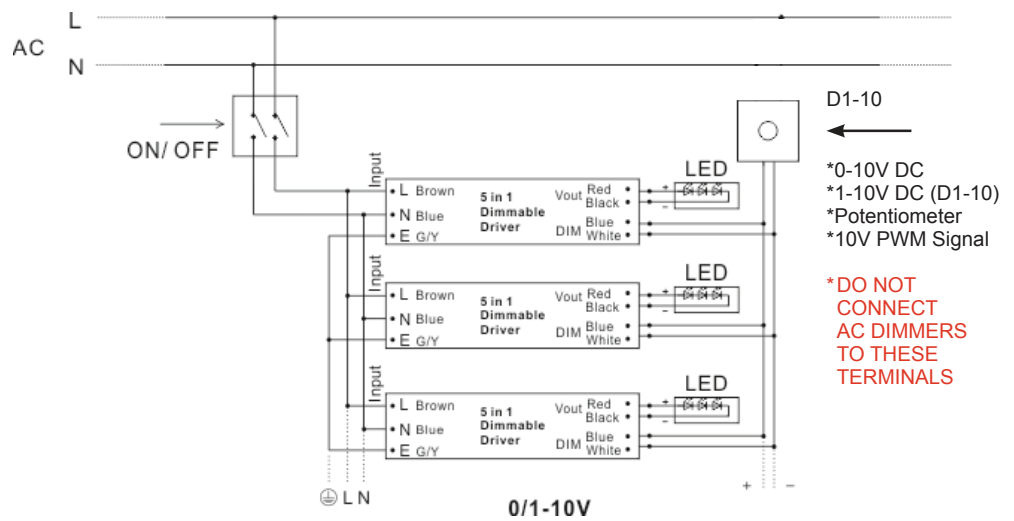

De-Rating Curve

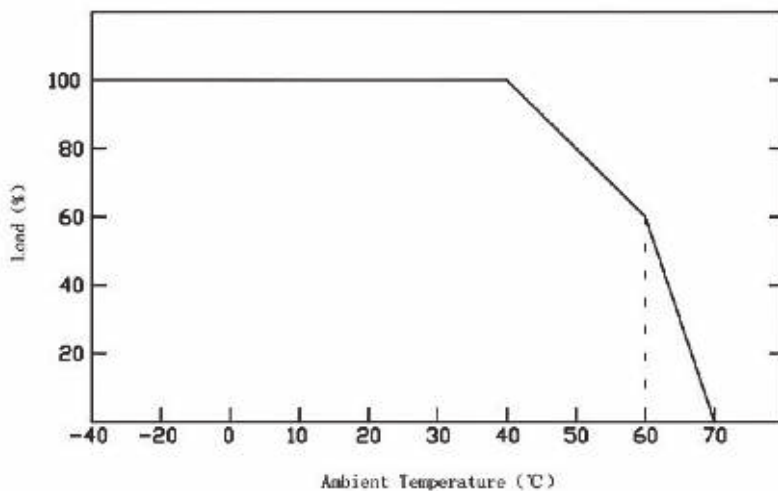

- If being used in higher ambient temperatures, ensure the load on the LED driver is de-rated in accordance with this chart. Failure to do so could lead to a premature failure, which is not covered by the warranty.

Power Source D1-10 1-10V Dimmer



- Dimming range: 10-100%
- Controls up to 30 LED Drivers
- Operating temp: 0-50°C
- Compatible with most switch wall plates

Important

- 1) Refer to Power Source Installation Manual.
- 2) Do Not Cover.
- 3) This LED driver should be installed by a qualified electrician.
- 4) Please make sure the LED driver is installed with adequate ventilation around it to allow for heat dissipation.
- 5) Ensure that all wiring is correct before testing in order to avoid damage to the LED driver, or the LEDs.