

HF Sensor with RF Wireless Transmission

HC028V/RF HC018V/RF
Tri-level Control Version

HYTRONIK®

Applications

RF wireless occupancy detector suitable for indoor use.

Suitable for building into the fixture:

- Carpark
- Classroom
- Staircase and corridor

Use for retrofit and new luminaire designs/installations



Features

- 24 hour daylight monitoring dawn/dusk sensor
- Tri-level dimming control based upon occupancy (also known as corridor function)
- 1-10V dimming control method
- Fast and simple commissioning/grouping of wireless sensor by the rotary switch
- Zero crossing detection circuit reduces in-rush current and prolongs relay life
- Loop-in and loop-out terminal for efficient installation
- 5-Year Warranty

Technical Data

Input Characteristics

Model No.	HC028V/RF	HC018V/RF
Mains voltage	220~240VAC 50/60Hz	
Stand-by power	<0.5W	
Load ratings	400VA(capacitive)	
Warming-up	20s	

Safety and EMC

EMC standard (EMC)	EN55015, EN61000-3-2/-3-3
Safety standard (LVD)	EN60669-1/-2-1, AS/NZS60669-1/-2-1
Radio Equipment (RED)	EN300440, EN301489-1/-3, EN62479
Certification	CE, RED, RCM, UKCA

Environment

Operation temperature	Ta: -20°C ~ +70°C
Case temperature (Max.)	Tc: +80°C
IP rating	IP20

Sensor & RF Data

Model No.	HC028V/RF	HC018V/RF
Sensor principle	High Frequency (microwave)	
Operation frequency	5.8GHz +/- 75MHz	
Transmission power	<0.2mW	
Detection range	Max. (∅ x H) 12m x 6m	
Detection angle	30° ~ 150°	
RF frequency	868MHz (FSK mode, default)	
RF transmission distance	30m indoor, 50m outdoor	
Setting adjustments:		
Sensitivity	10% / 50% / 75% / 100%	
Hold time	5s ~ 30min (selectable)	
Daylight threshold	2 ~ 50 lux, disabled	
Stand-by period	0s ~ 1h, +∞ (selectable)	
Stand-by dimming level	10% / 20% / 30% / 50%	

CE UKCA RED IP20

RF Transceiver HC028V/RF

**can serve as both primary and secondary*

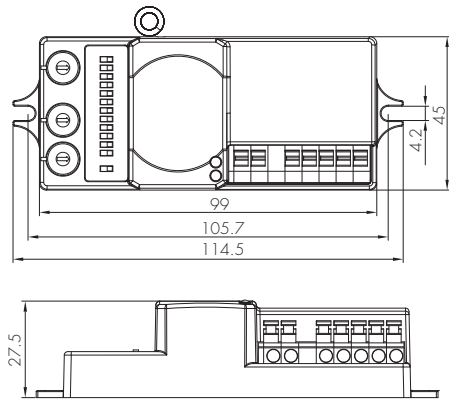
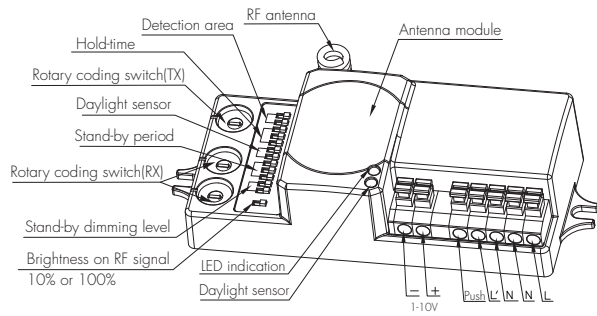

RF Transmitter HC018V/RF

**primary only*

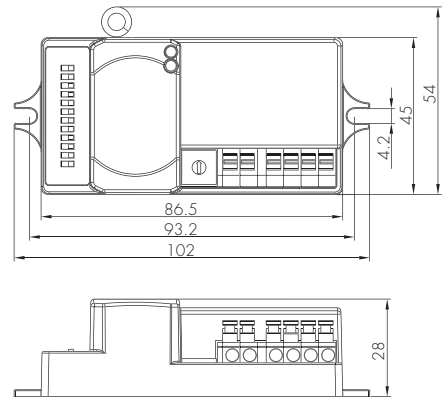
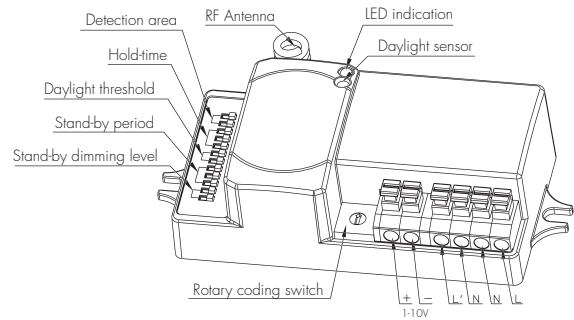

RF Receiver HC023RF

**secondary, on-off control*

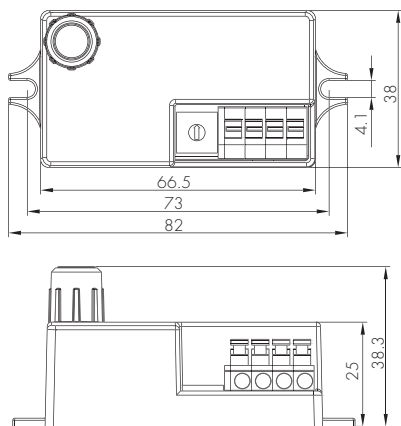
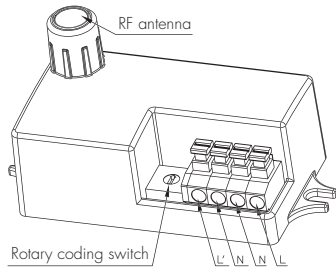

RF Receiver HC024RF

**secondary, dimming control*

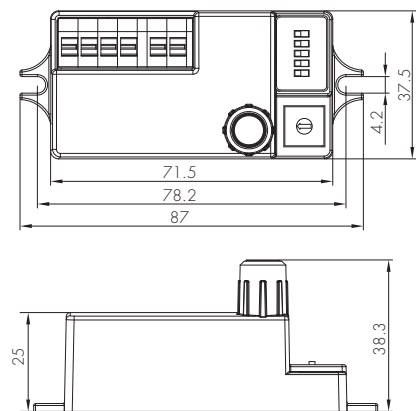
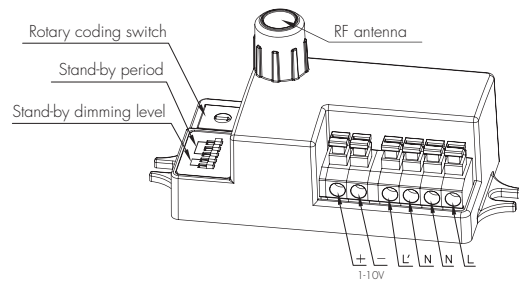

This is a combination of motion sensor and RF radio wave wireless transmission, which is perfect solution for retrofit projects. The motion detected by 1 sensor (the primary unit) can pass onto other pre-defined individuals (the secondary units) though RF transmission. The primary can trigger unlimited number of secondaries within the transmission range (30 meters indoor and 100 meters in the open area).

With fixed address code technology, it's easy to set up transmission groups. Up to 16 different groups can be created. Optional transmission frequency of 433/868 MHz, thanks to FSK technology. Easy installation and free of wiring!

Distance Recommended between Sensors

Pay attention: The RF signal could be affected by big metal plate & wireless devices such as GSM mobile antenna, strong Wifi signal, ultra high-voltage cable which emits frequent electromagnetic waves radiation, which may interfere with the RF transmission and communication! Please always check the application environment before mass installation!

We recommend the mounting distance between sensors to be more than 4m to avoid sensors from being false-triggered.

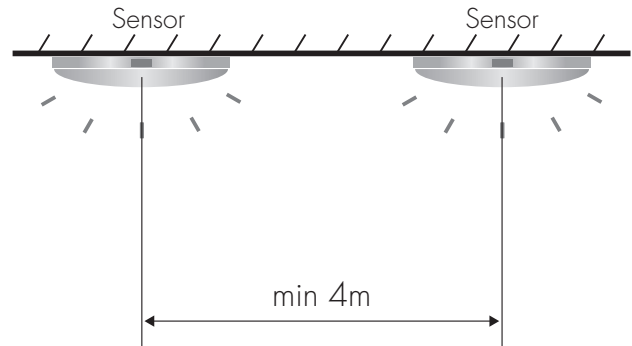

Functions and Features

1 24h Daylight Monitoring Function (for primary only)

Our innovative and patented software enables our antenna with built-in daylight sensor to provide a "smart photocell" function. This function is activated when stand-by period is set to "+∞".

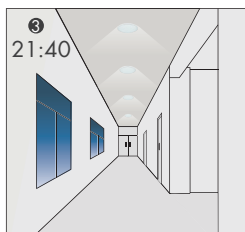
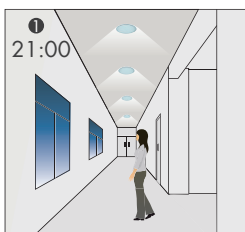

Settings on this demonstration:

- Hold-time: 10min
- Daylight threshold: 50lux
- Stand-by dimming level: 10%
- Stand-by period: +∞

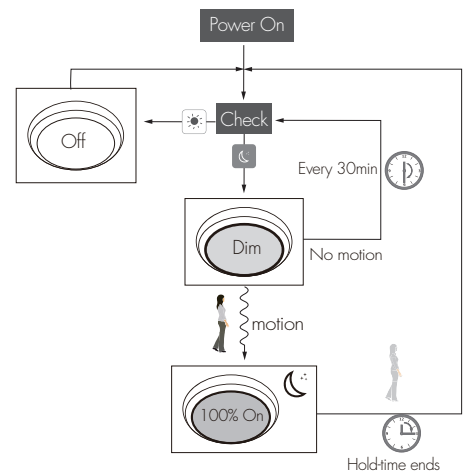
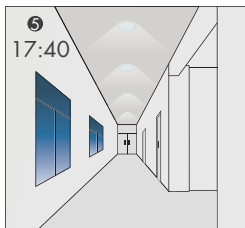
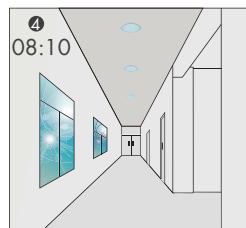
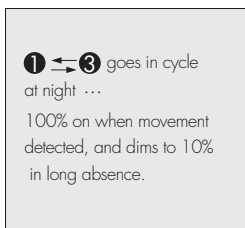

2 Manual Override (for HC028V/RF only)

This sensor reserves the access of manual override function for end-user to switch on/off, or adjust the brightness by push-switch, which makes the product more user-friendly and offers more options to fit some extra-ordinary demands:

* Short Push (< 1s): on/off function;

On → Off: the light turns off immediately and cannot be triggered ON by motion until the expiration of pre-set hold-time. After this period, the sensor goes back to normal sensor mode.

Off → On: the light turns on and goes to sensor mode, no matter if ambient Lux level exceeds the daylight threshold or not. When manually push on the primary via the push switch, it sends out the RF "ON" signal to all secondaries in the same group.

The secondary turns on the light (or keeps the light off if pre-set threshold on the secondary unit is below ambient lux level).

* Long Push (> 1s): adjust the hold-time brightness level between 10% and 100%.

Note: if end-user do not want this manual override function, just leave the "push" terminal unconnected to any wire.

3 Zero-cross Relay Operation

Designed in the software, sensor switches on/off the load right at the zero-cross point, to ensure that the in-rush current is minimised, enabling the maximum lifetime of the relay.

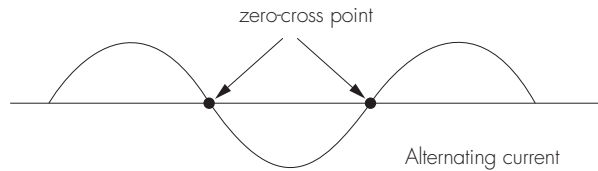

4 Loop-in and Loop-out Terminal

Double L N terminal makes it easy for wire loop-in and loop-out, and saves the cost of terminal block and assembly time.

Typical Applications

A For staircase (HC028V/RF serves as both primary and secondary)

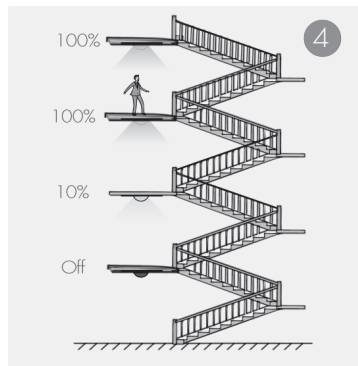
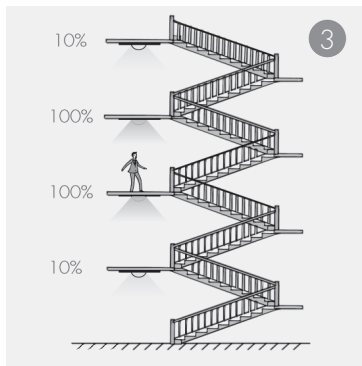
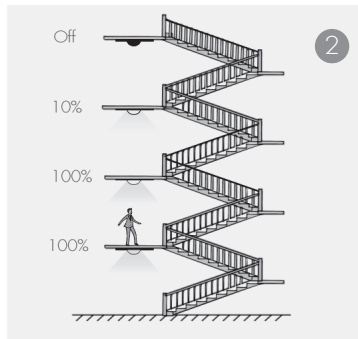
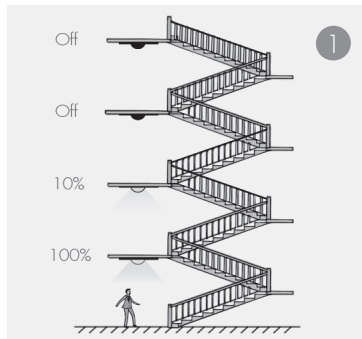

1 The 1st sensor detects motion, it turns the light on 100% and sends signal to the 2nd sensor at the same time. The 2nd light is switched on at stand-by brightness.

2 The person walks to the 2nd floor, the 2nd sensor turns the light on 100%, meanwhile, the 3rd light is switched to stand-by brightness.

3 The person walks to the 3rd floor, the 3rd sensor turns on the light 100%, meanwhile, the 4th light is switched to stand-by brightness. The 1st light is dimmed to stand-by brightness after hold-time.

4 The person walks to the 4th floor, the 4th sensor turns on the light 100%, meanwhile, the next light is switched to stand-by brightness. The 1st light is off after stand-by period and the 2nd light is dimmed to stand-by brightness.

Note: by selecting the brightness DIP switch, the secondary can either turn the light 100% on or dim the light to stand-by dimming level upon receiving the RF signal from the primary.

RF Grouping (Maximum 16 channels)

Using a screwdriver to adjust the rotary switch on both the transmitter unit (primary) and receiving unit (secondary), and keep them pointing at the same channel, the grouping is automatically completed. 16 channels (maximum 16 groups) available for both the primary & secondary unit.

Note: RX1 and RX2 can receive RF signals from two different channels/primarys.

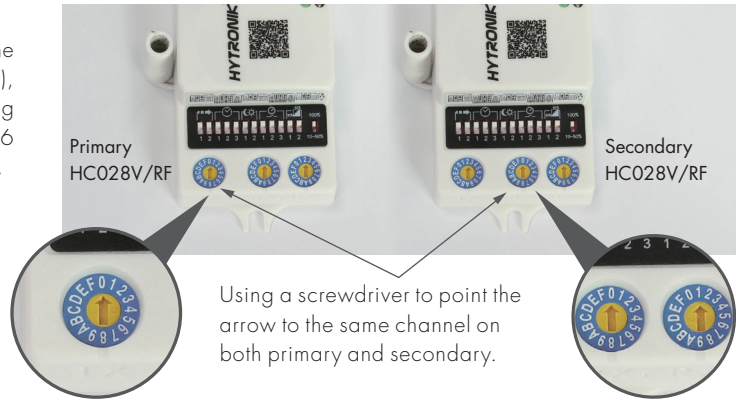

Using a screwdriver to point the arrow to the same channel on both primary and secondary.

B For staircase and corridor (HCO28V/RF as both primary and secondary, HCO24RF as secondary)

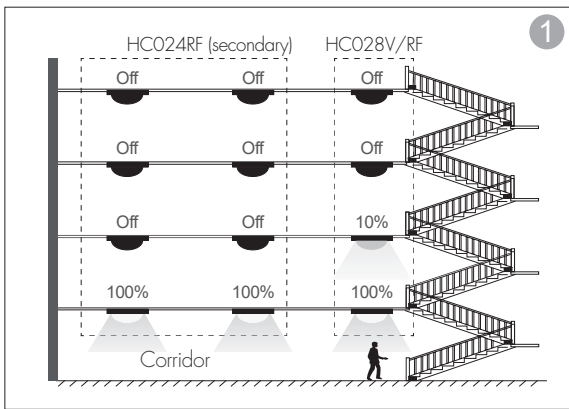

While the 1st sensor detects motion on the 1st floor, it switches the light on 100% and sends signal to all secondary units. All HCO24RF on the 1st floor turn on 100% and the HCO28V/RF on the 2nd floor goes to stand-by level.

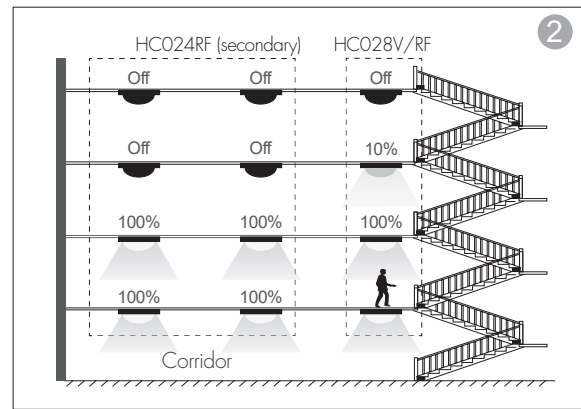

The person walks to the 2nd floor, the 2nd HCO28V/RF switches the light on 100%. All HCO24RF on the 2nd floor turn the light on 100% and the HCO28V/RF on the 3rd floor goes to stand-by level.

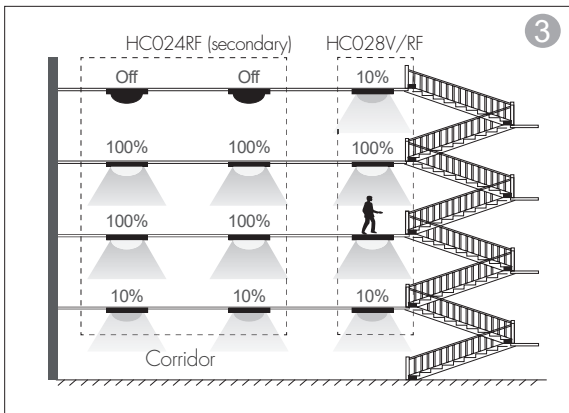

When walks to the 3rd floor, the 3rd HCO28V/RF switches the light on 100%. All HCO24RF on the 3rd floor turn the light on 100% and the HCO28V/RF on the 4th floor goes to stand-by level. Meanwhile, the lights on the 1st floor are dimmed to stand-by level after hold-time.

Note: the lights in the corridor go off directly after hold-time if controlled by HCO23RF.

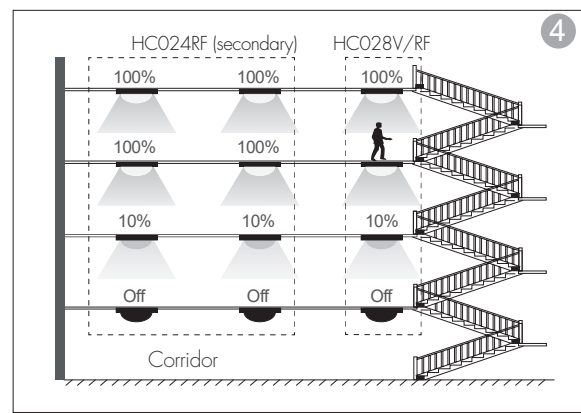

The person walks to the 4th floor, the 4th HCO28V/RF switches the light on 100%. All HCO24RF on the 4th floor turn the light on 100% and the next HCO28V/RF goes to stand-by level. Meanwhile, all sensors on the 1st floor turn the light off after stand-by period, and all lights on the 2nd floor dim to stand-by level after hold-time.

RF Grouping (Maximum 16 channels)

Using a screwdriver to adjust the rotary switch on both the transmitters unit (primary) and receiving unit (secondary), and keep them pointing at the same channel, the grouping is automatically completed. 16 channels (maximum 16 groups) available for both the primary & secondary unit.

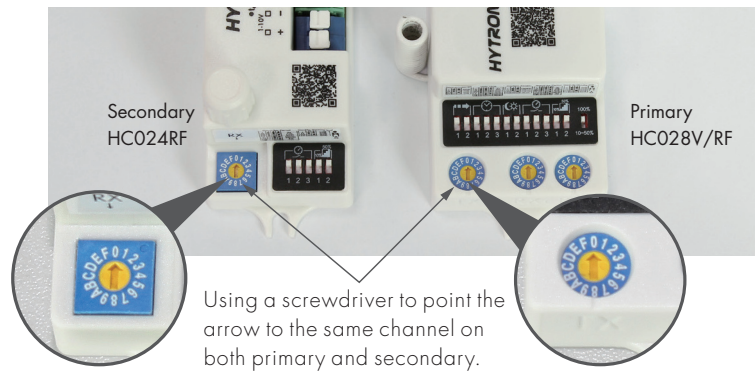

Using a screwdriver to point the arrow to the same channel on both primary and secondary.

C For carpark (HC018V/RF as primary and HC024RF as secondary)

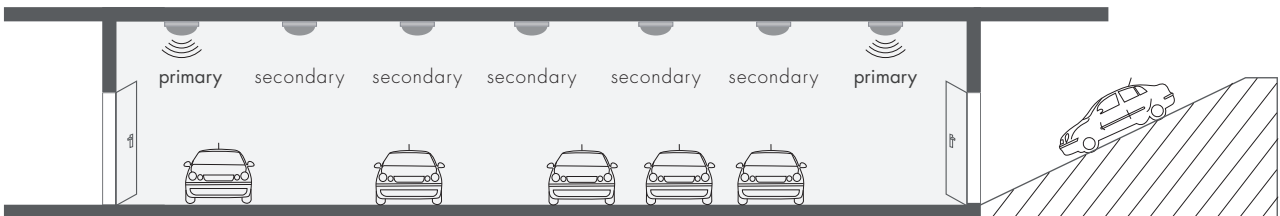

With sufficient natural light, the sensor is not triggered by motion.

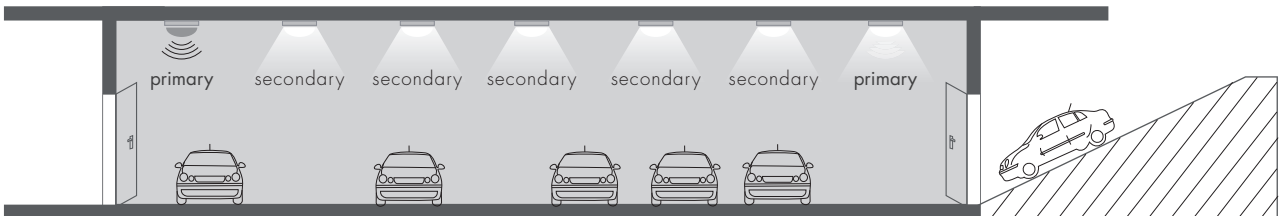

With insufficient natural light, the sensor is triggered by motion, the primary switches on the light and send RF signal to all salves.

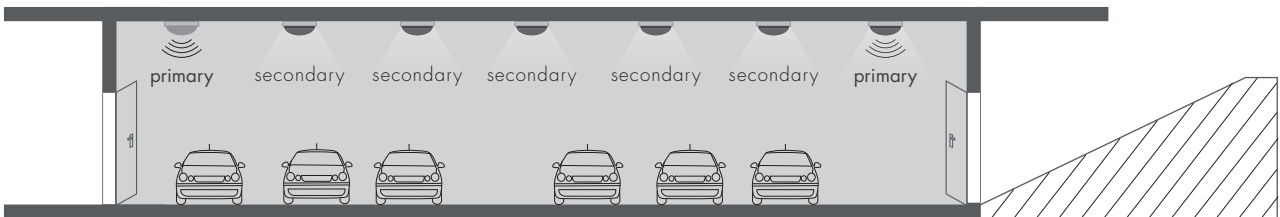

After the hold-time, the whole group of lamps dim to pre-defined dimming level when no movement detected.

Note: the lights go off directly after hold-time when controlled by HC023RF.

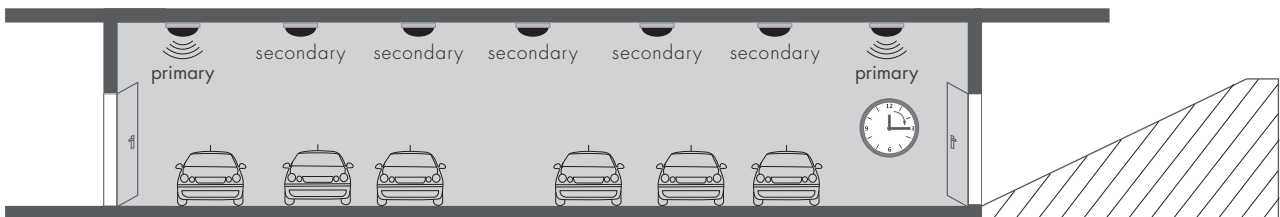

The whole group of lamps switch off automatically after the stand-by period.

RF Grouping (Maximum 16 channels)

Using a screwdriver to adjust the rotary switch on both the transmitter unit (primary) and receiving unit (secondary), and keep them pointing at the same channel, the grouping is automatically completed. 16 channels (maximum 16 groups) available for both the primary & secondary unit.

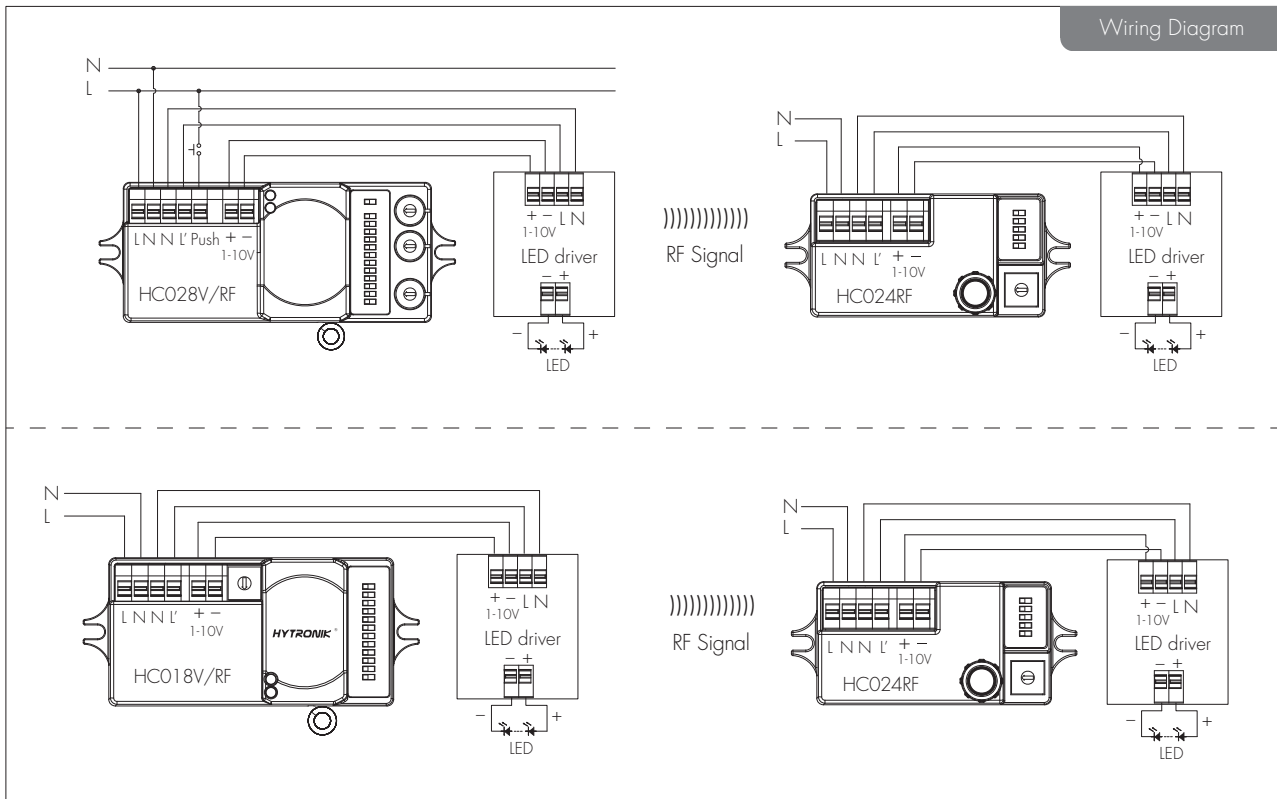
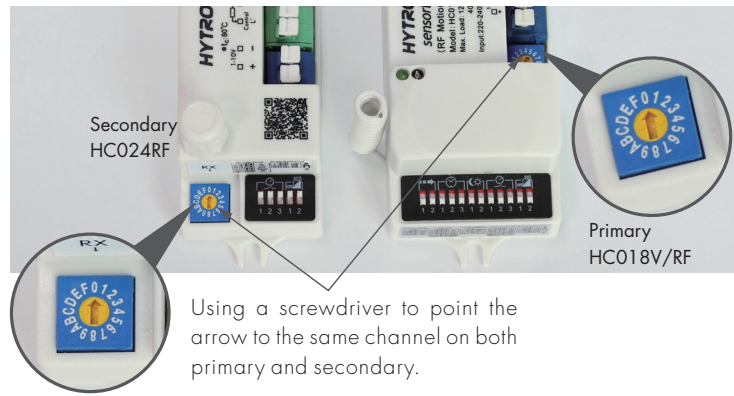

DIP Switch Settings (HC028V/RF & HC018V/RF)

1 Detection Range

Sensor sensitivity can be adjusted by selecting the combination on the DIP switches to fit precisely for each specific application.

	1	2	
I	●	●	100%
II	●	○	75%
III	○	●	50%
IV	○	○	10%

I – 100%
 II – 75%
 III – 50%
 IV – 10%

2 Hold Time

Select the DIP switch configuration for the light on-time after presence detection. This function is disabled when natural light is sufficient.

	1	2	3	
I	●	●	●	5s
II	●	●	○	30s
III	●	○	●	1min
IV	●	○	○	5min
V	○	●	●	10min
VI	○	●	○	20min
VII	○	○	○	30min



- I – 5s
- II – 30s
- III – 1min
- IV – 5min
- V – 10min
- VI – 20min
- VII – 30min

3 Daylight Threshold

Set the level according to the fixture and environment. The light will not turn on if ambient lux level exceeds the daylight threshold preset.

Please note that the ambient lux level refers to internal light reaching the sensor.

Disabling the daylight sensor will put the sensor into occupancy detection only mode.

	1	2	
I	●	●	Disable
II	●	○	50Lux
III	○	●	10Lux
IV	○	○	2Lux



- I – Disable
- II – 50Lux
- III – 10Lux
- IV – 2Lux

4 Stand-by period (corridor function)

This is the time period you would like to keep at the low light output level before it is completely switched off in the long absence of people.

Note: "0s" means on/off control; "+∞" means the stand-by time is infinite and the light is effectively controlled by the daylight sensor, off when natural light is sufficient and automatically on at dimming level when insufficient.

	1	2	3	
I	●	●	●	0s
II	●	●	○	10s
III	●	○	●	1min
IV	●	○	○	5min
V	○	●	●	10min
VI	○	●	○	30min
VII	○	○	●	1H
VIII	○	○	○	+∞



- I – 0s
- II – 10s
- III – 1min
- IV – 5min
- V – 10min
- VI – 30min
- VII – 1H
- VIII – +∞

5 Stand-by dimming level

The setting is used to select the desired dimmed light level used in periods of absence for enhanced comfort and safety.

	1	2	
I	●	●	10%
II	●	○	20%
III	○	●	30%
IV	○	○	50%



- I – 10%
- II – 20%
- III – 30%
- IV – 50%

DIP Switch Settings (HC024RF)

1 Stand-by period (corridor function)

This is the time period you would like to keep at the low light output level before it is completely switched off in the long absence of people.

Note: "0s" means on/off control; "+∞" means the stand-by period is infinite and the fixture never switches off but stays at dimming level.

	1	2	3	
I	●	●	●	0s
II	●	●	○	10s
III	●	○	●	1min
IV	●	○	○	5min
V	○	●	●	10min
VI	○	●	○	30min
VII	○	○	●	1H
VIII	○	○	○	+∞



- I – 0s
- II – 10s
- III – 1min
- IV – 5min
- V – 10min
- VI – 30min
- VII – 1H
- VIII – +∞

2 Stand-by dimming level

The setting is used to select the desired dimmed light level used in periods of absence for enhanced comfort and safety.

	1	2	
I	●	●	10%
II	●	○	20%
III	○	●	30%
IV	○	○	50%



- I – 10%
- II – 20%
- III – 30%
- IV – 50%

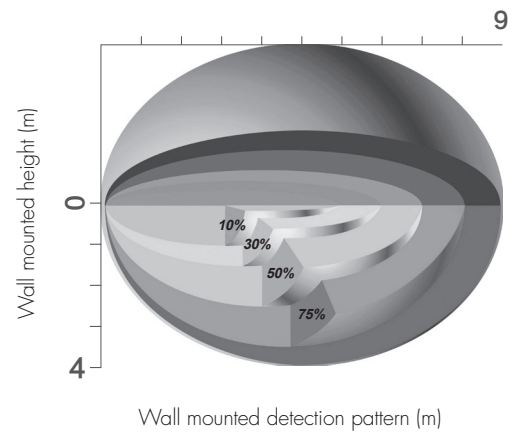
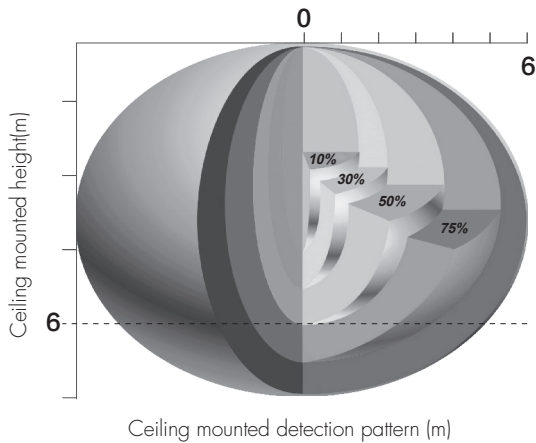

Additional Information / Documents

1. Regarding precautions for microwave sensor installation and operation, please kindly refer to [www.hytronik.com/download ->knowledge ->Microwave Sensors - Precautions for Product Installation and Operation](http://www.hytronik.com/download->knowledge->Microwave+Sensors+-+Precautions+for+Product+Installation+and+Operation)
2. Regarding precautions for RF sensor installation and operation, please kindly refer to [www.hytronik.com/download ->knowledge ->RF Sensors - Precautions for Product Installation and Operation](http://www.hytronik.com/download->knowledge->RF+Sensors+-+Precautions+for+Product+Installation+and+Operation)
3. Regarding Hytronik standard guarantee policy, please refer to [www.hytronik.com/download ->knowledge ->Hytronik Standard Guarantee Policy](http://www.hytronik.com/download->knowledge->Hytronik+Standard+Guarantee+Policy)